



# MILAN RATHOD

MECHATRONICS ENGINEER  
PROJECT INVOLVEMENT: DIGIMAN



# PROJECT: DIGIMAN

- Research and development of piezo-sensorized advance tool for chatter suppression in the machining process

- Goals:
- Chatter Suppresion during machining process
  - Increase Stability limit of the machining process
  - Increase productivity, decrease production as well as operational cost and production time

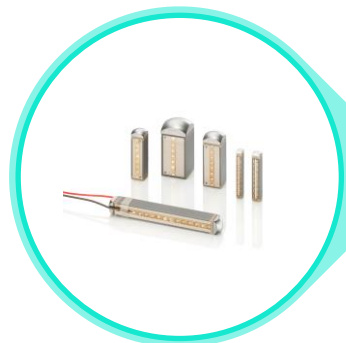

Piezo-electric stack actuator

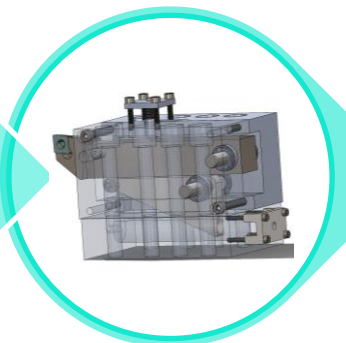

Custom Designed Tool Holder

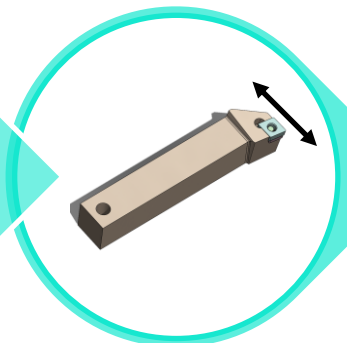

Controlled vibration in feed direction impose

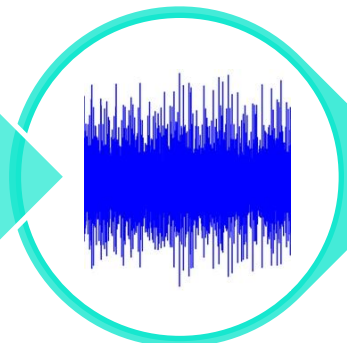

Vibration and Force signal analysis

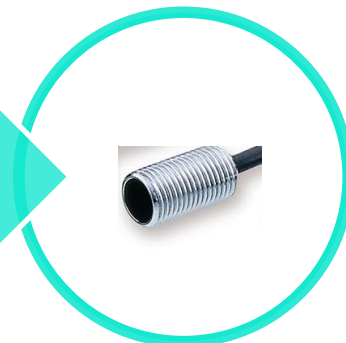

Tool tip displacement Feedback signal measured by sensor

# DIGIMAN



## PROJECT OUTLINE

- 1 *Literature Review & Concept Development*
- 2 *Simulation Model Development & Physibility check of the concept effectiveness*
- 3 *Selection of the piezoelectric actuator to satisfy the simulation requirement & finalize the design of custom tool holder along with piezo actuator housing*
- 4 *Manufacturing of the tool holder and Initial testing of the piezoelectric actuator*
- 5 *Final experimental validation of the simulation results & vibration attenuation*

# DIGIMAN



# CUSTOM TOOL HOLDER DESIGN FOR PIEZO ACTUATOR HOUSING

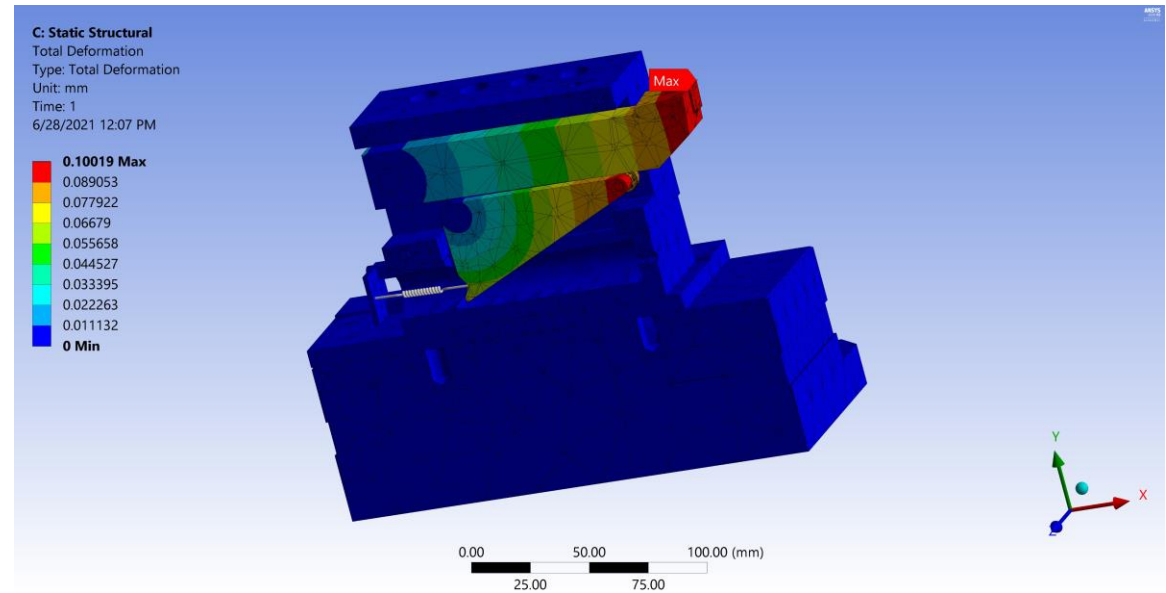
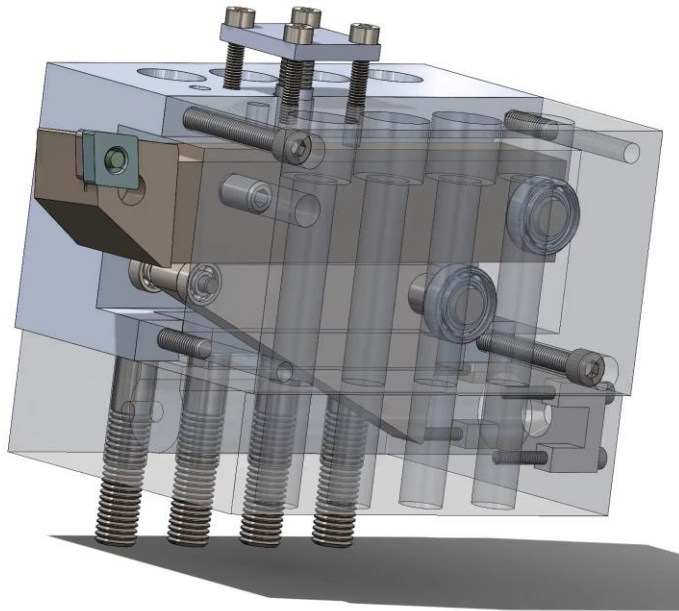

# STABILITY IMPROVEMENT

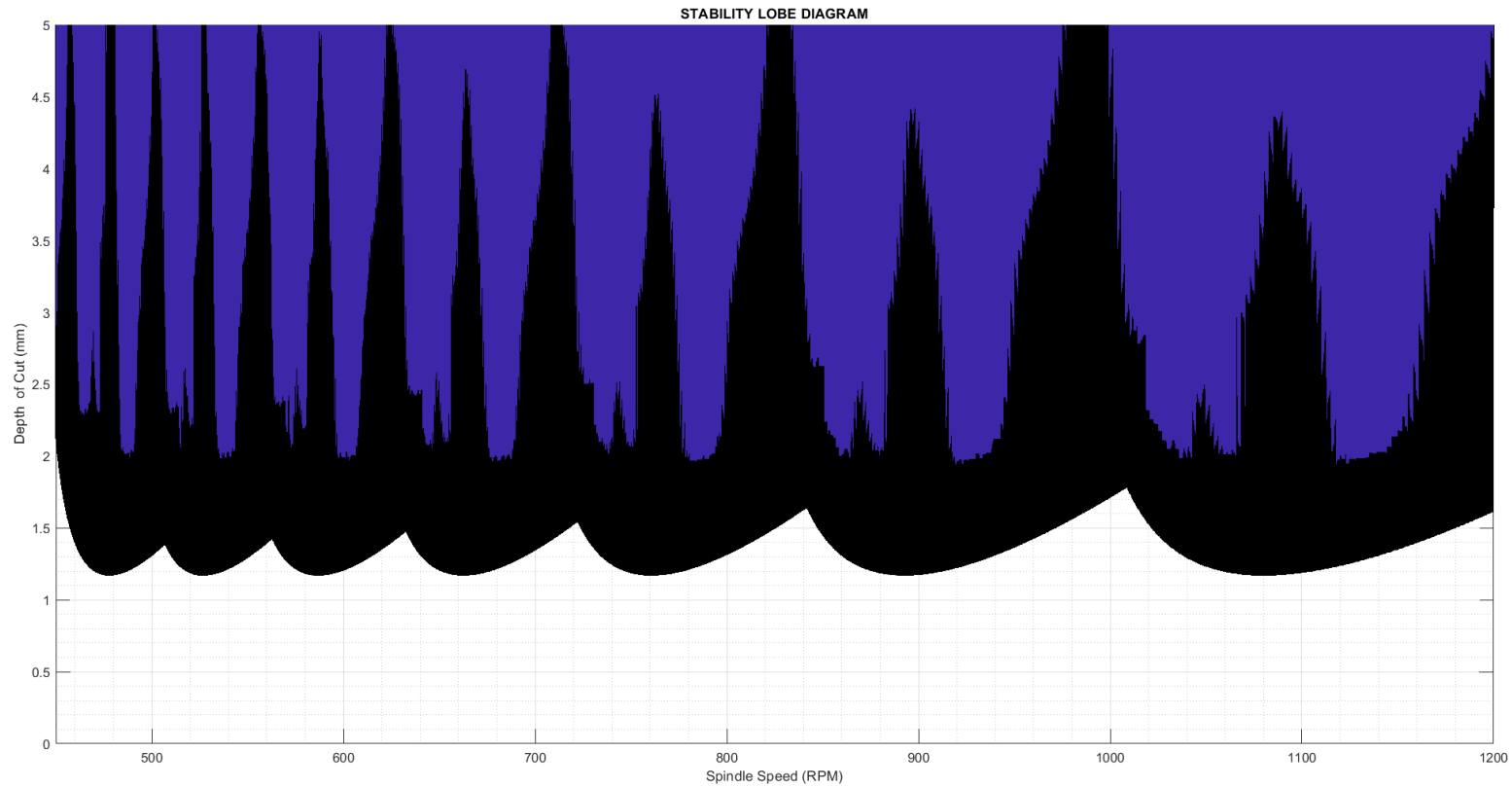

# STABILITY IMPROVEMENT

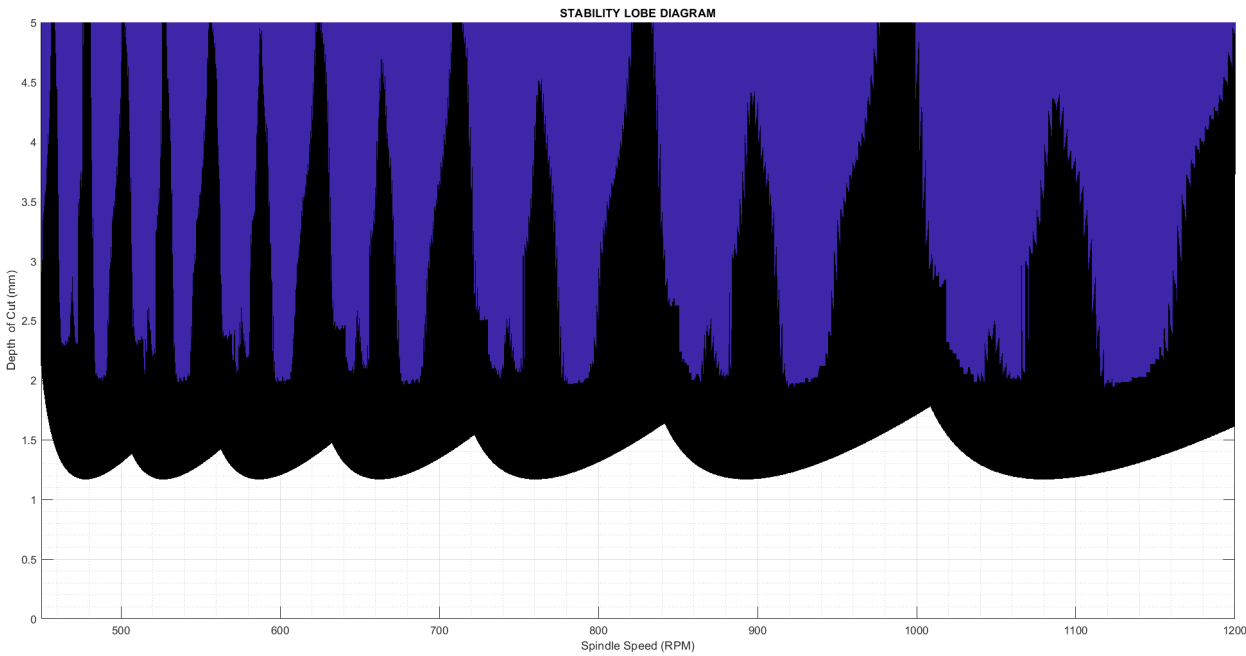

# STABILITY IMPROVEMENT

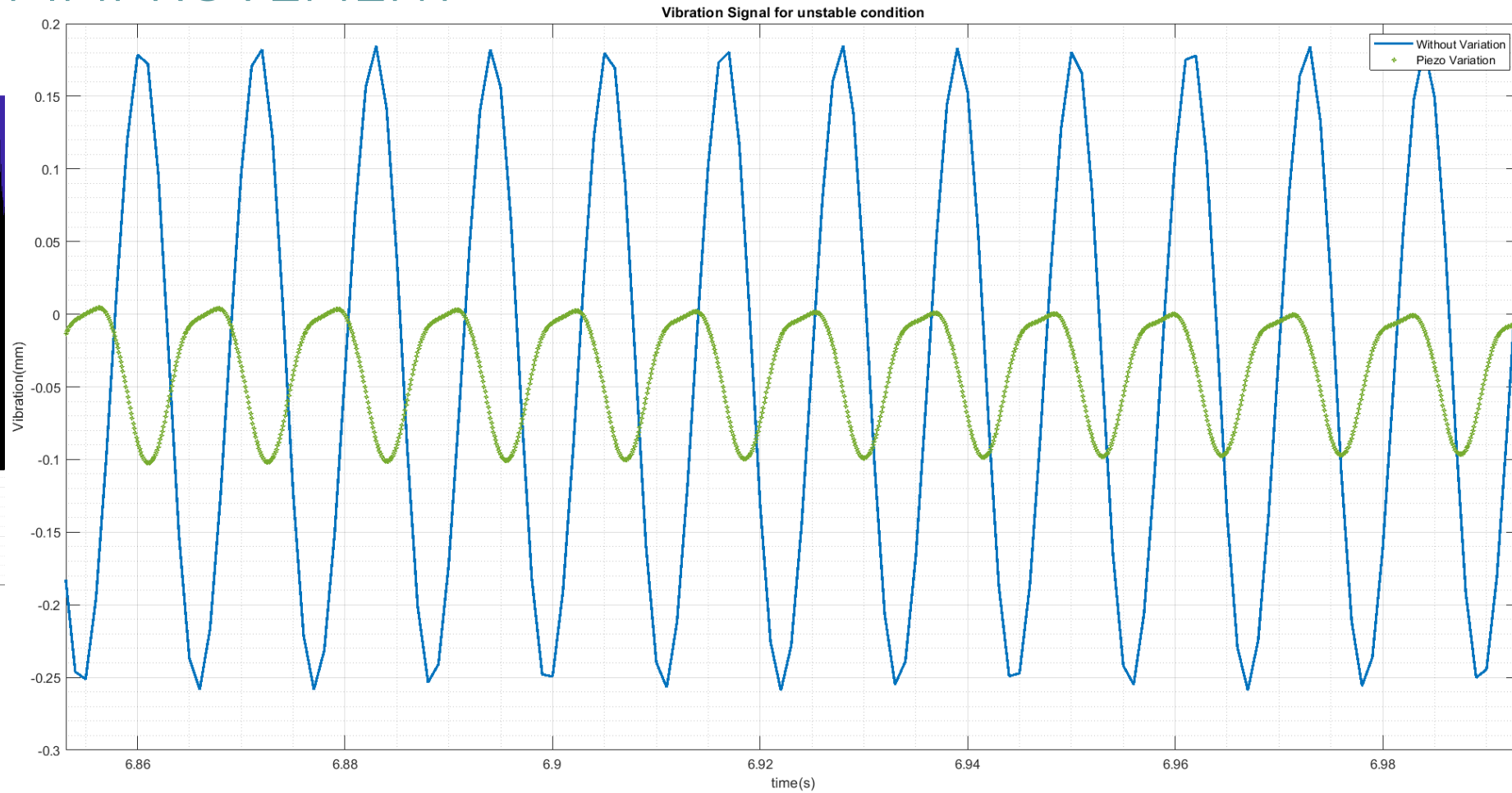
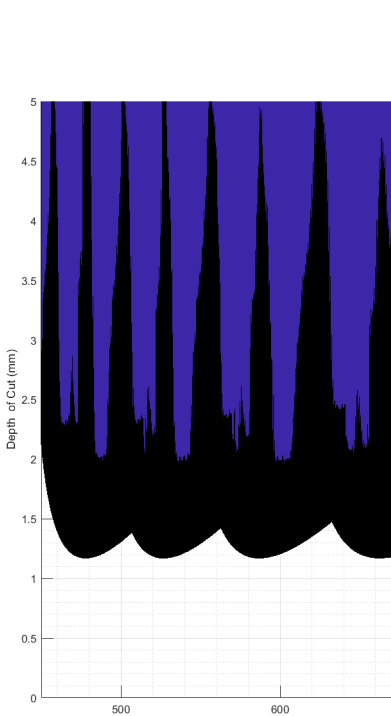

# STABILITY IMPROVEMENT

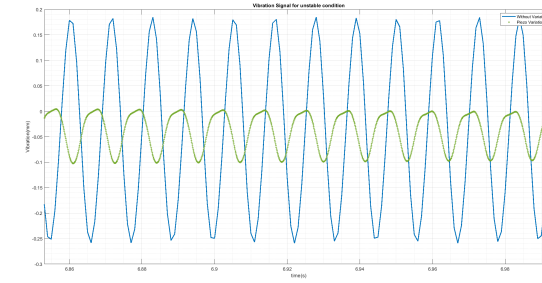
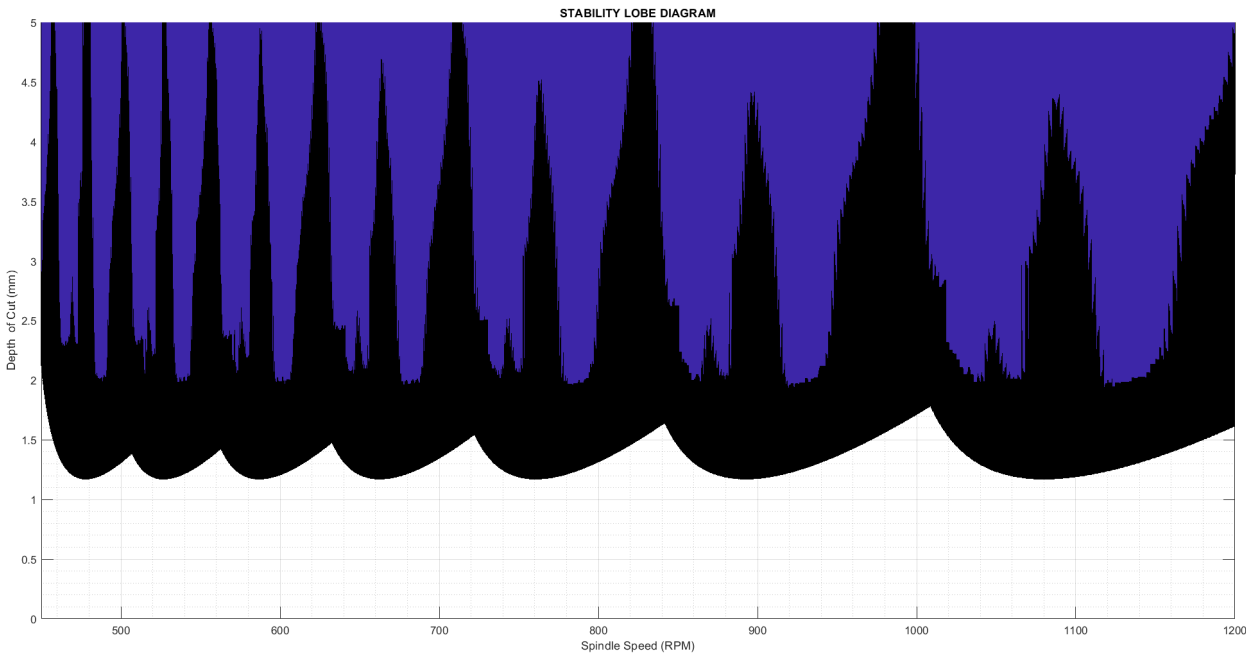

# STABILITY IMPROVEMENT

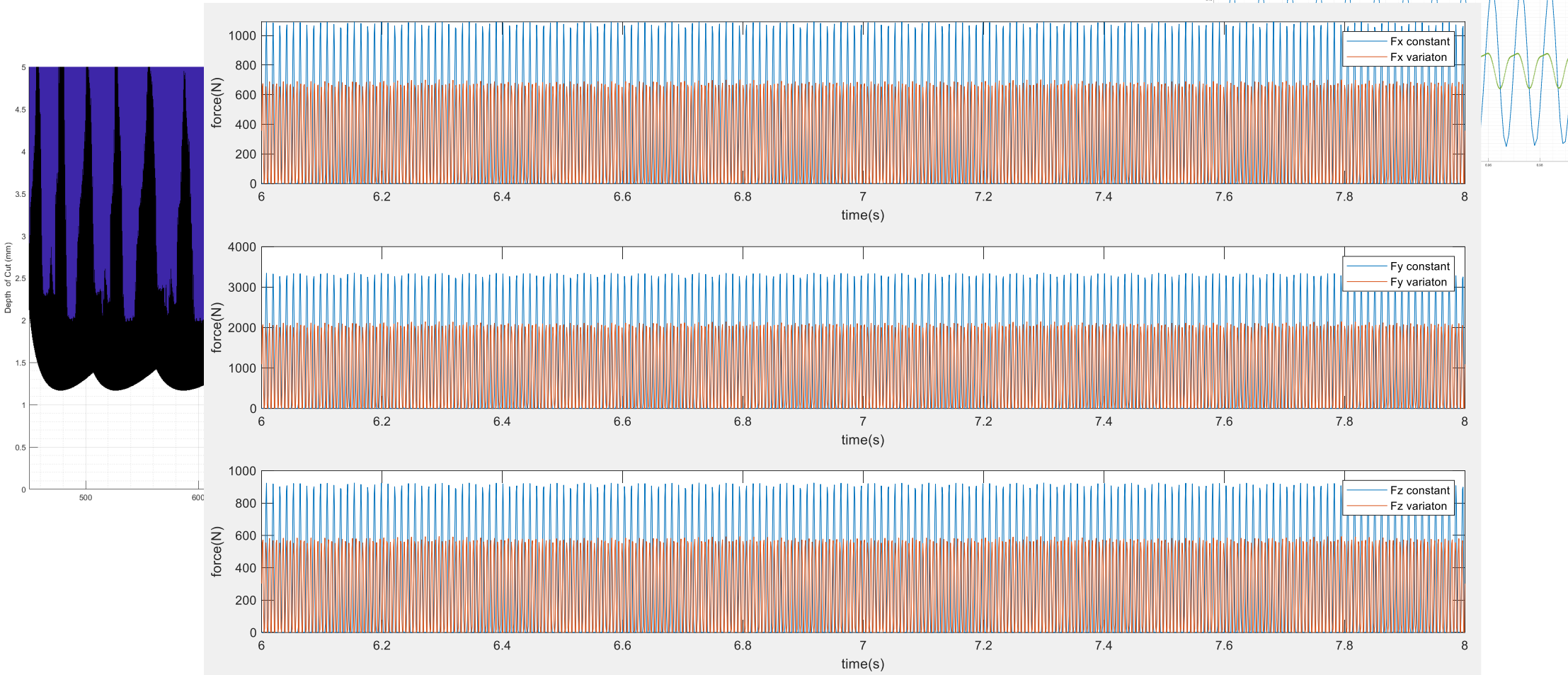

# STABILITY IMPROVEMENT

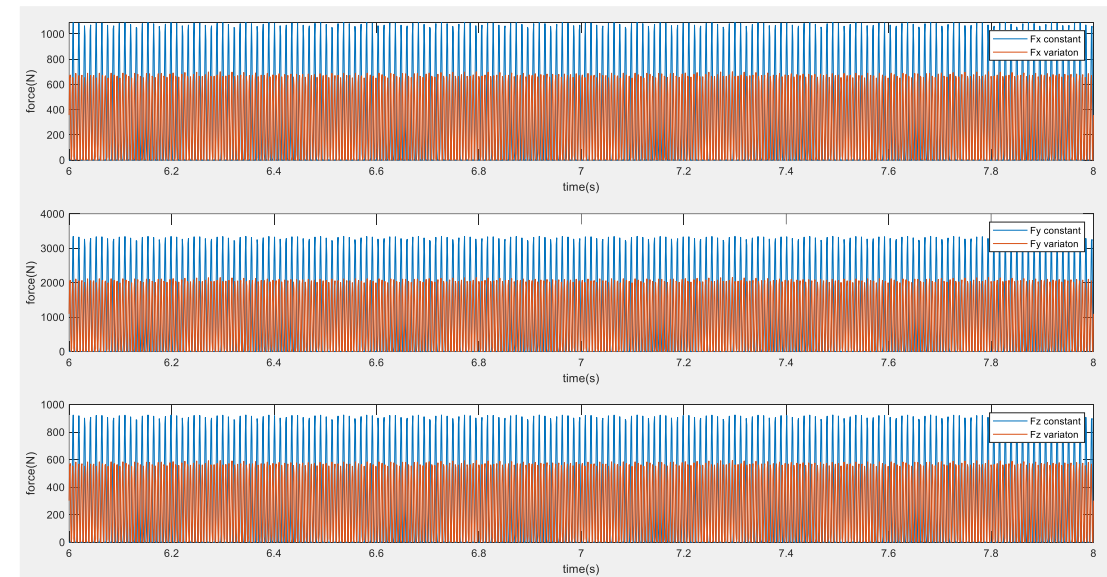
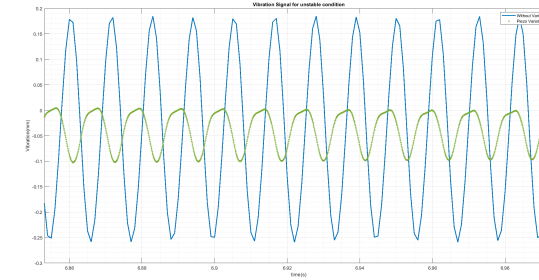
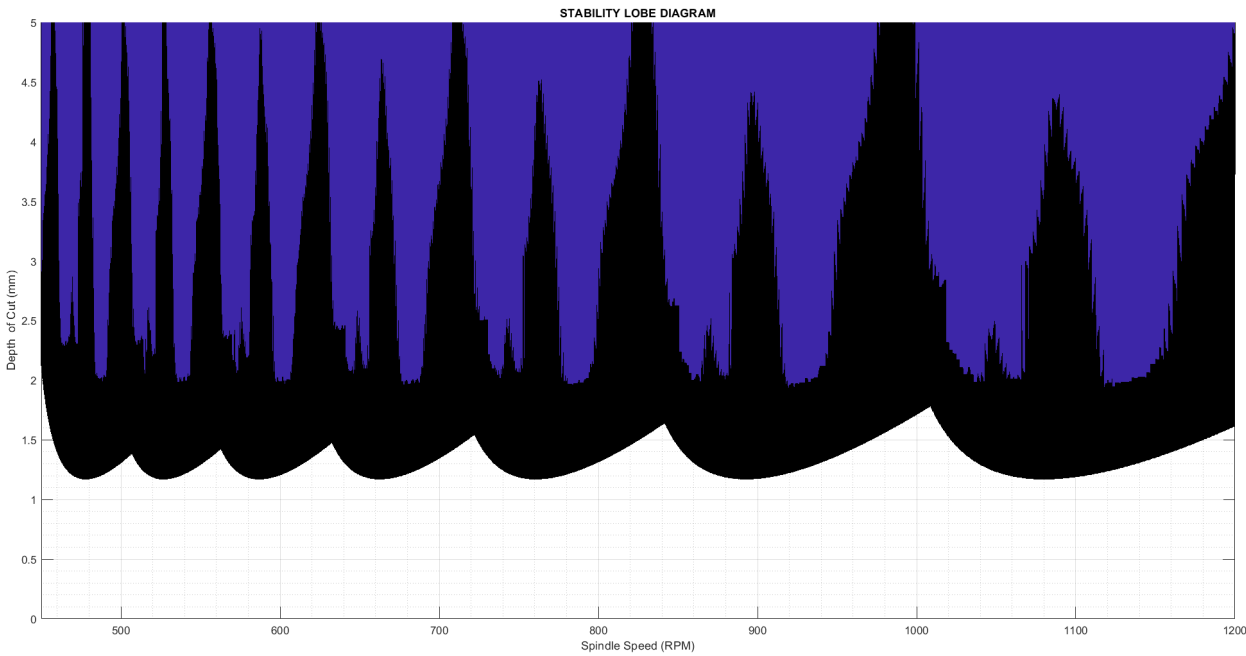

# INITIAL TESTING OF PIEZOELECTRIC ACTUATOR

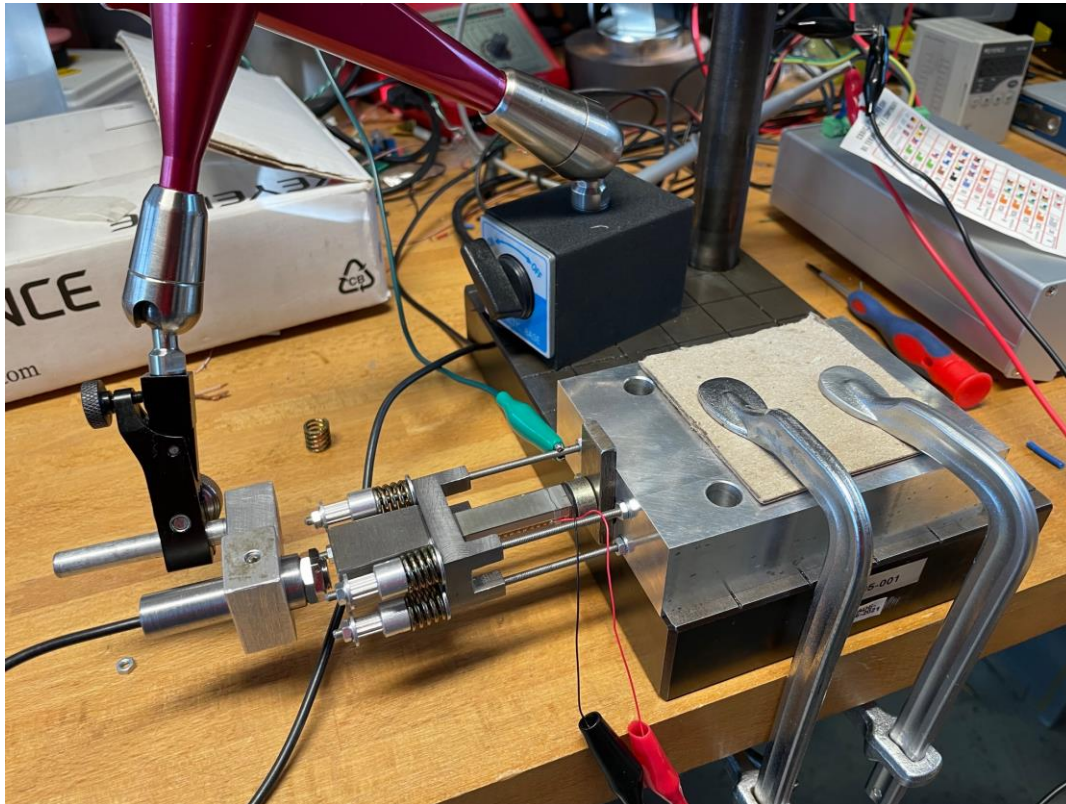

## OUTCOME

Attenuate the machining vibrations



Increase the stability limit of the process



Increase Productivity and reduce manufacturing time

# NEW METHOD FOR ANALYTICAL FORMULATION FULL DISCRETIZATION METHOD

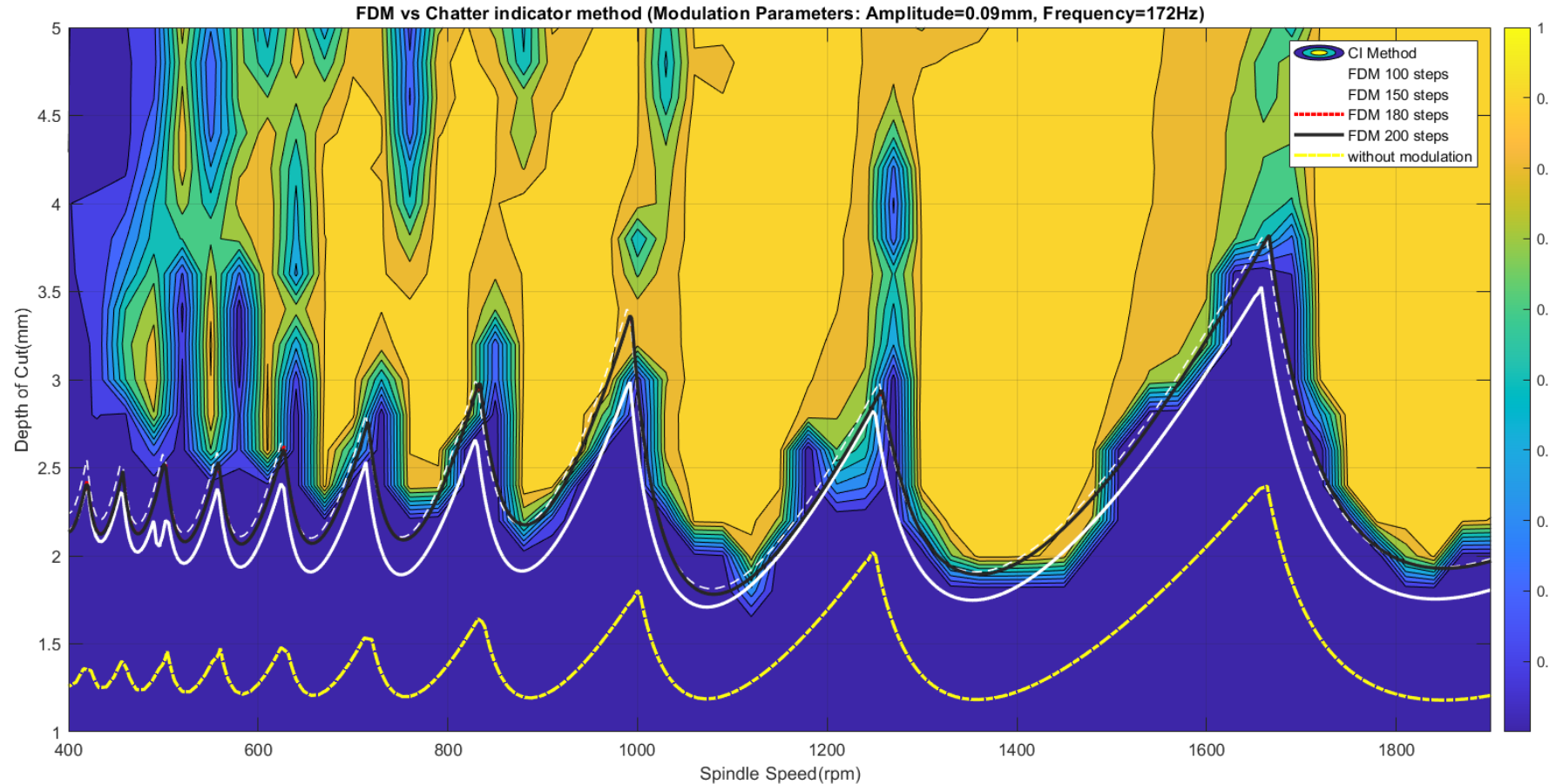

# SETUP FOR STATIC VIBRATION TEST AT THE TOOL TIP

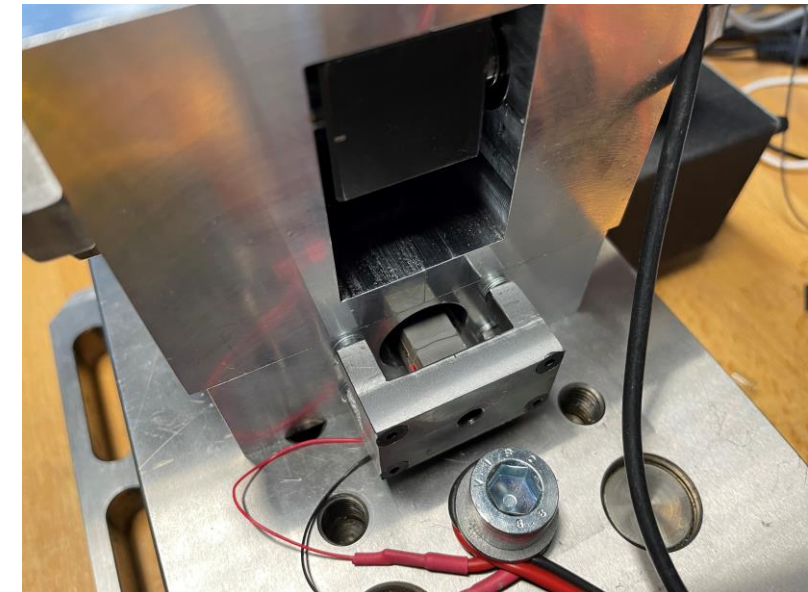
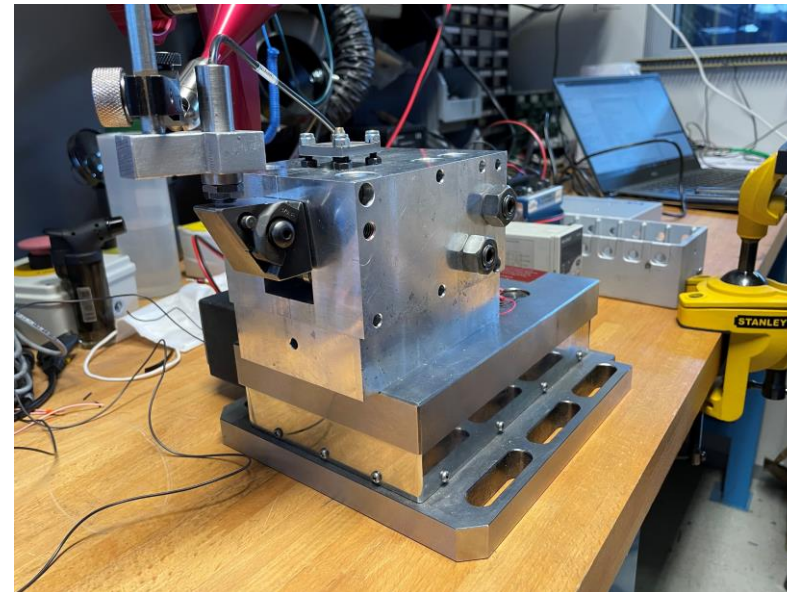
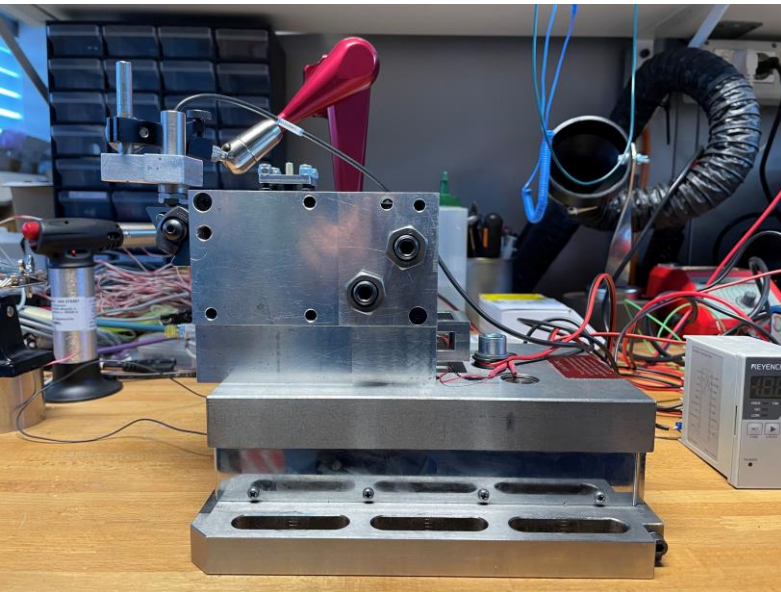

# STATIC VIBRATION TEST AT THE TOOL TIP

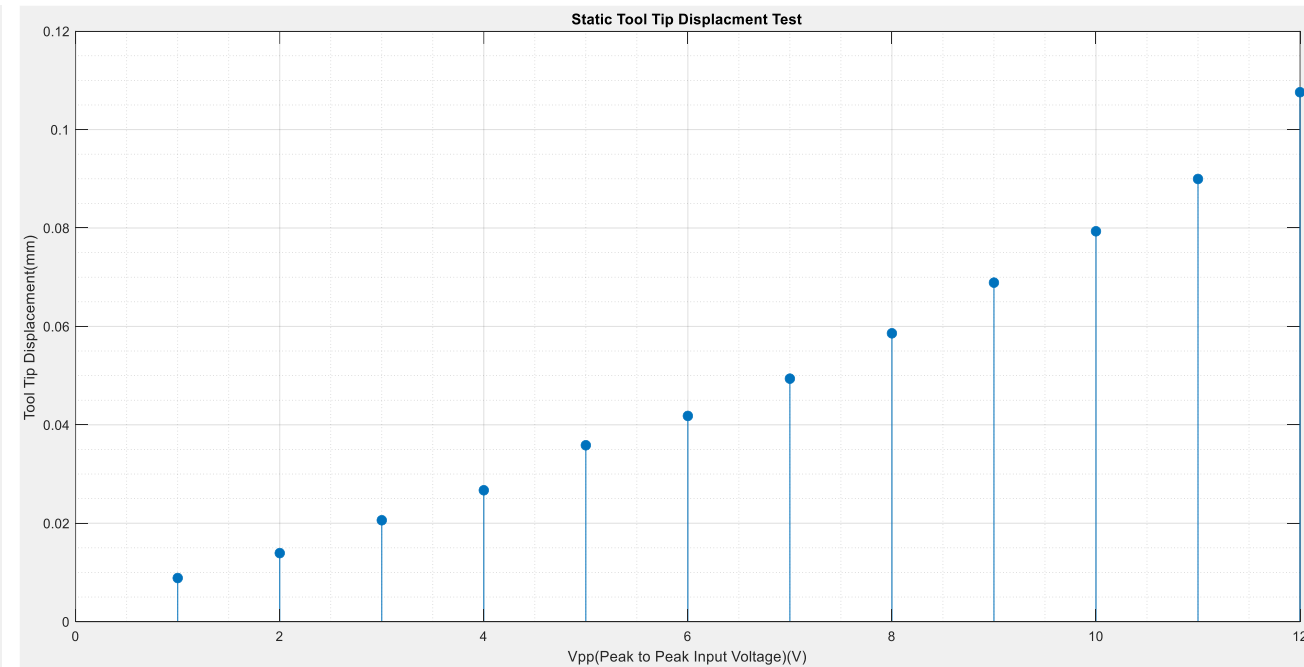
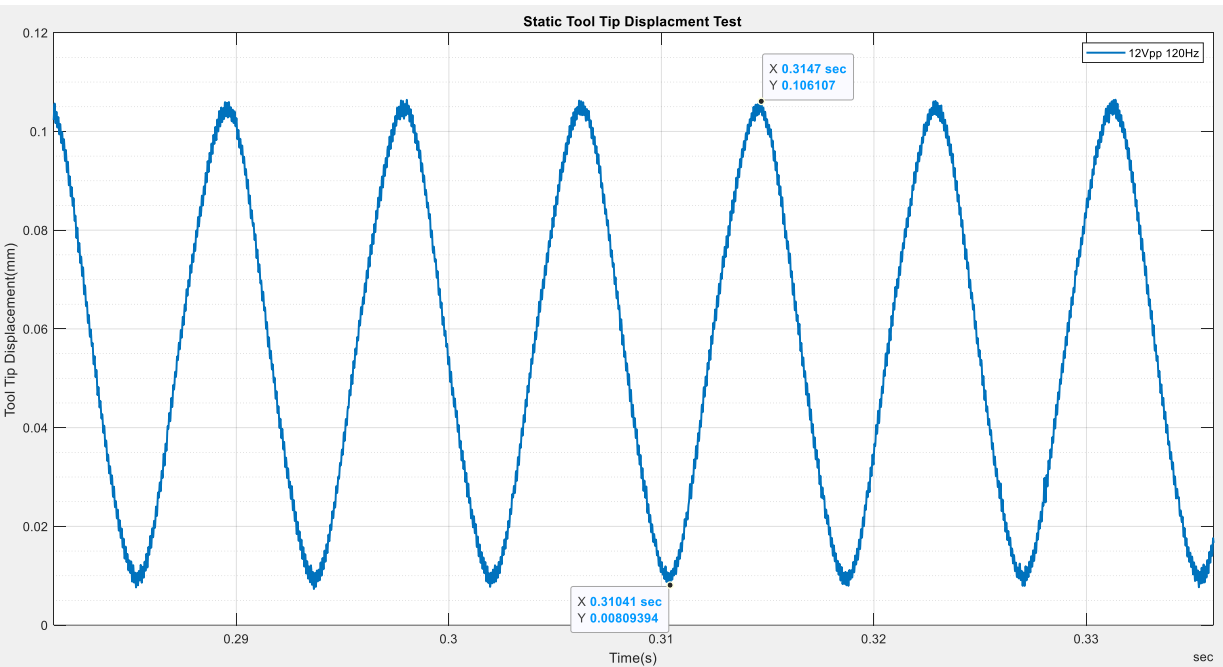

# DYNAMIC VIBRATION ATTENUATION TEST SETUP

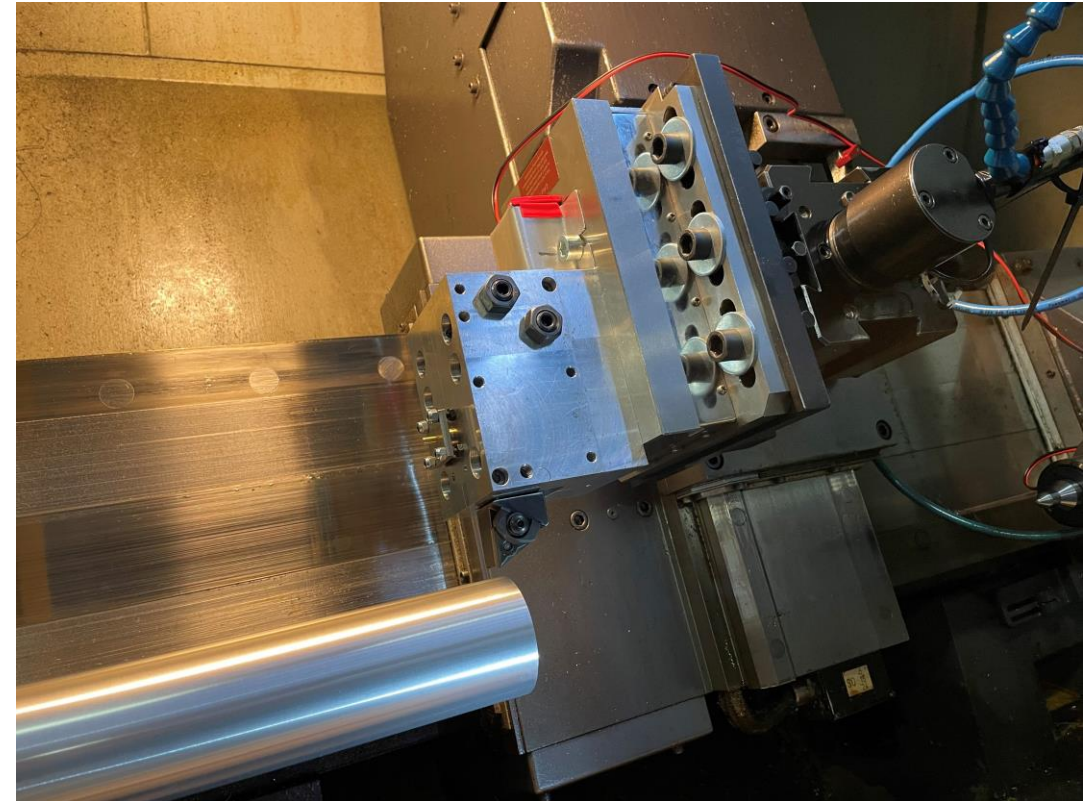
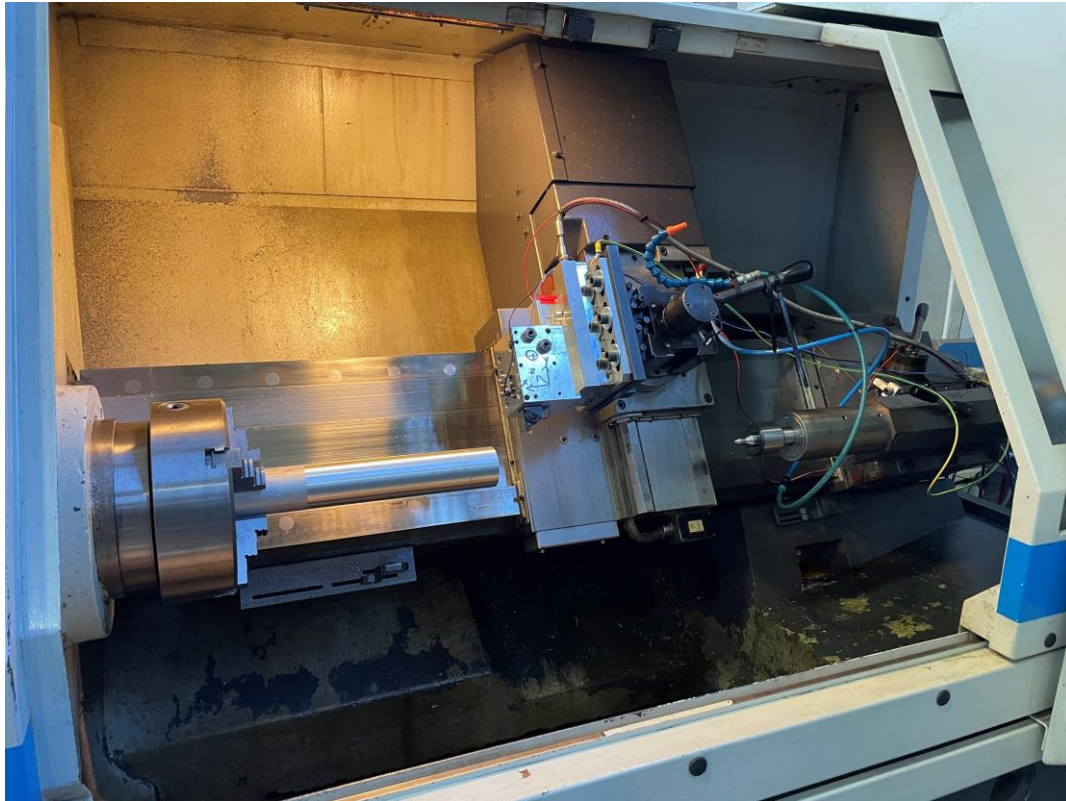



**GRAZIE**

